

# HY-330

fall semester 2024

## Introduction to telecommunication systems theory

University of Crete  
Computer Science Department

Stefanos Papadakis



# Tx Chain Overview

- Channel Coding
  - Forward Error Correction (FEC)
  - Interleaver
- Mapping
  - QAM/PSK
- Modulation
  - OFDM/CDMA
- DAC
- Filtering



# Telecommunication System

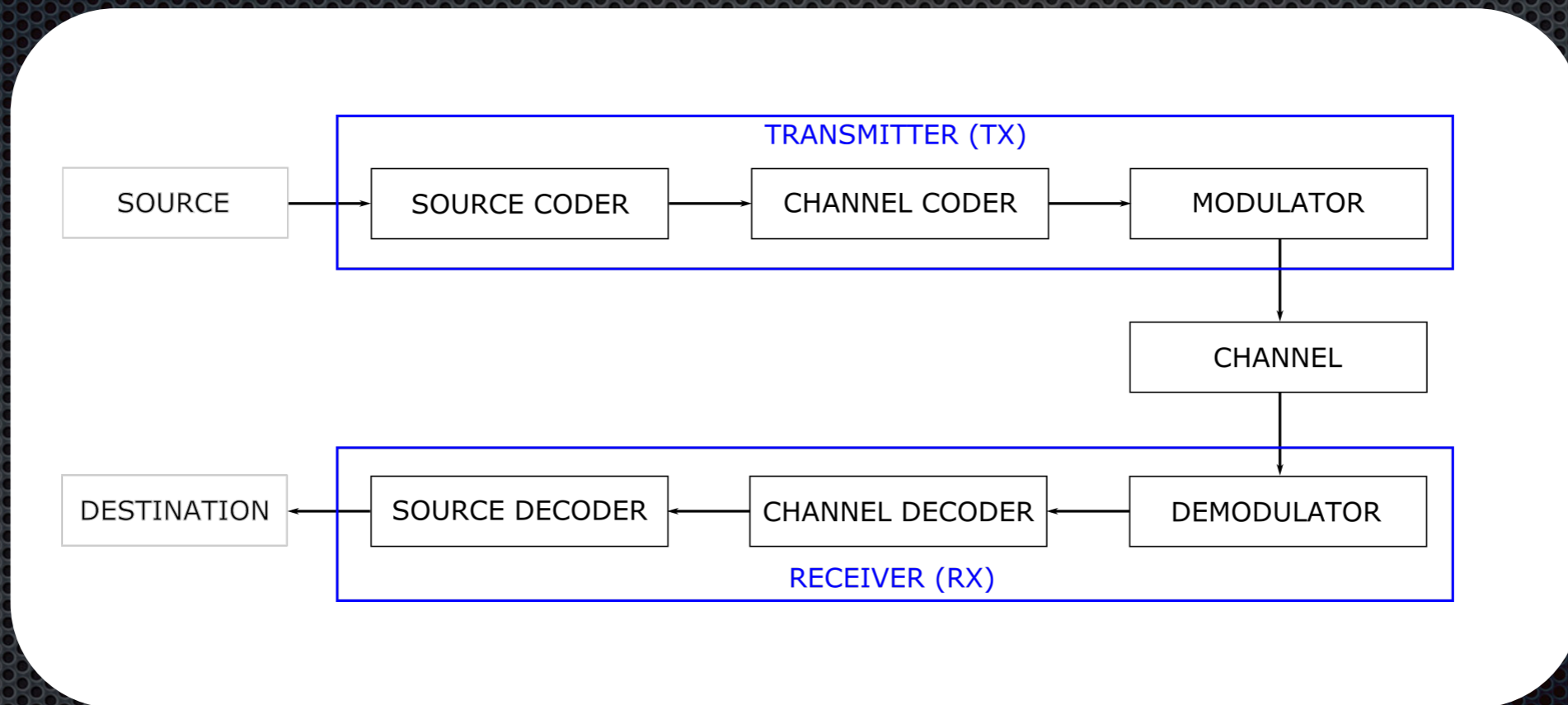



# Basic Transmitter

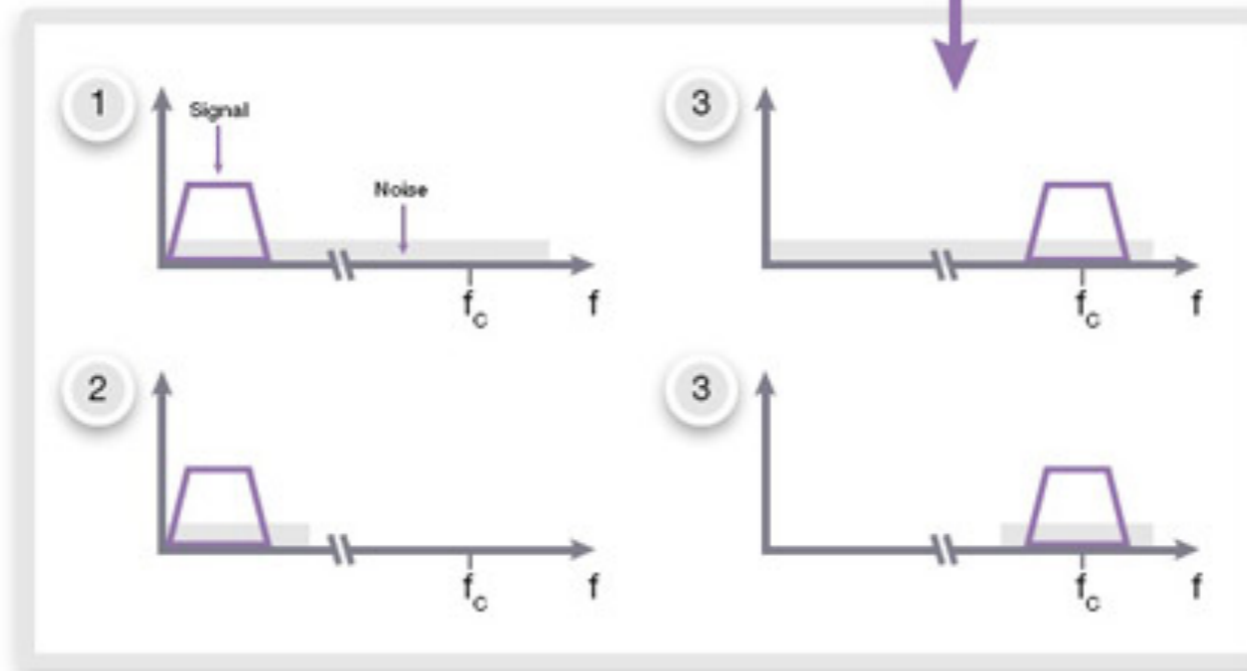
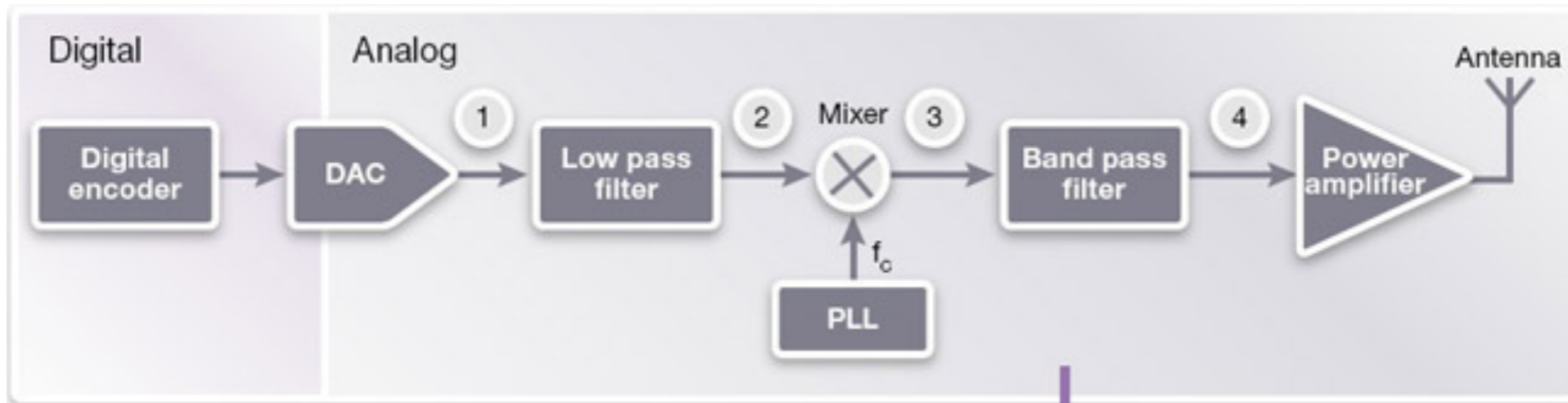



# SDR

- Software Reconfigurable Receiver & Transmitter hardware
- Limited only by the DAC/ADC characteristics and host interface
  - Sampling Frequency, Resolution
  - Interface throughput
- Most of the signal processing is implemented in software
- Needs high computational resources on host computer, but provides total freedom in the signal processing

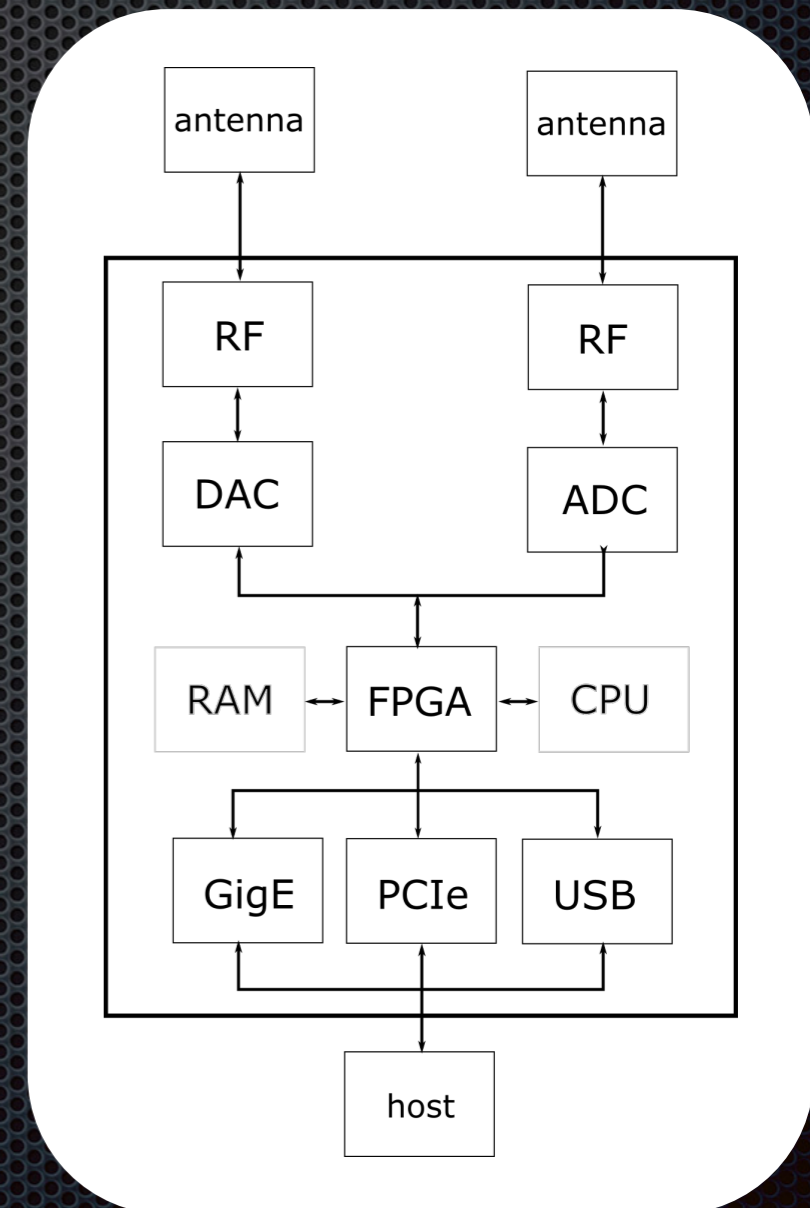



# Typical SDR

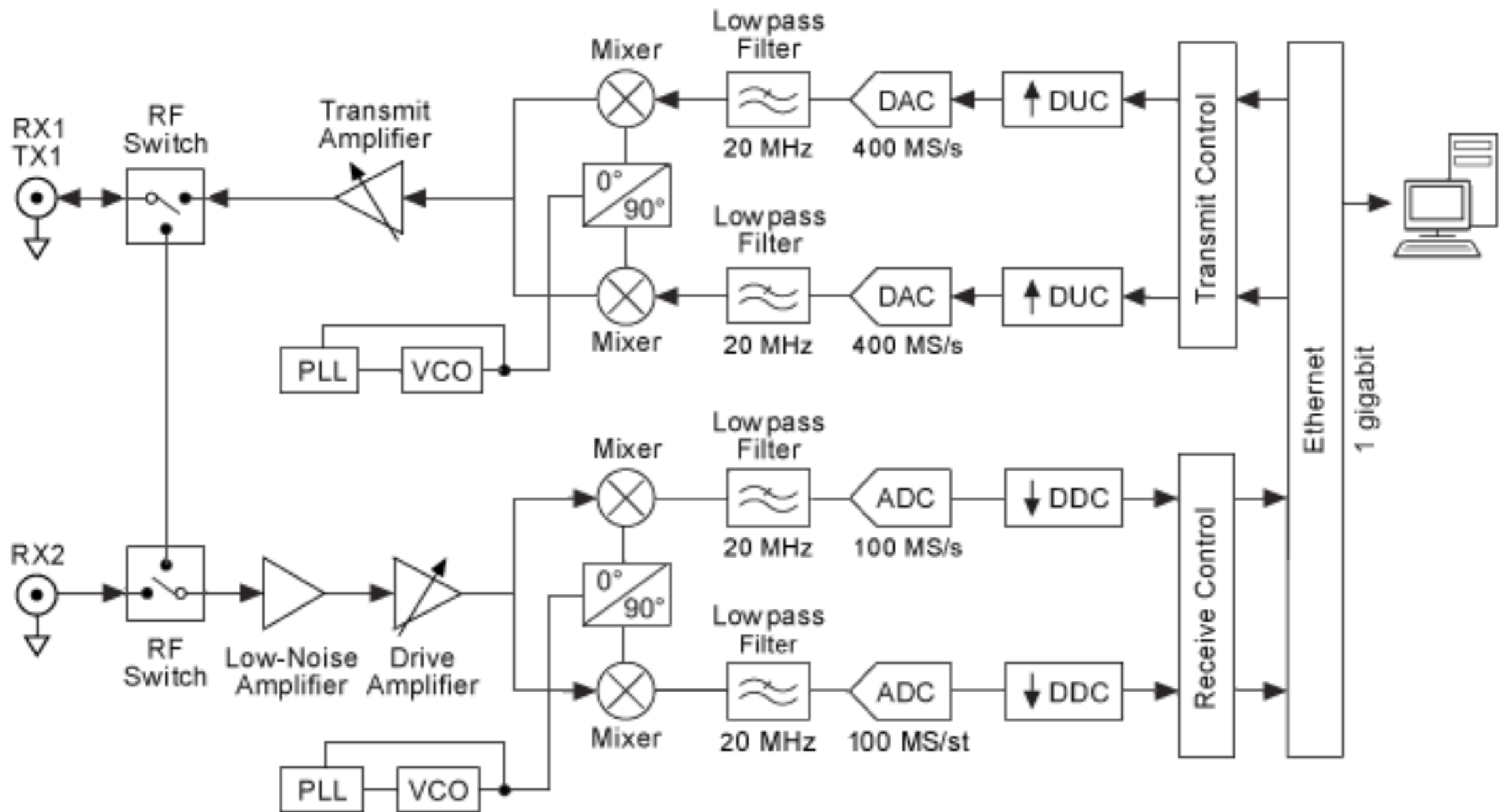



# IEEE 802.11a

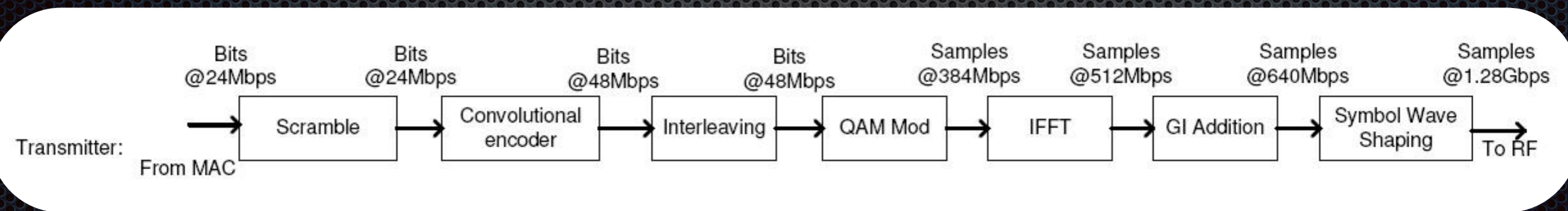



# 802.11 transceiver

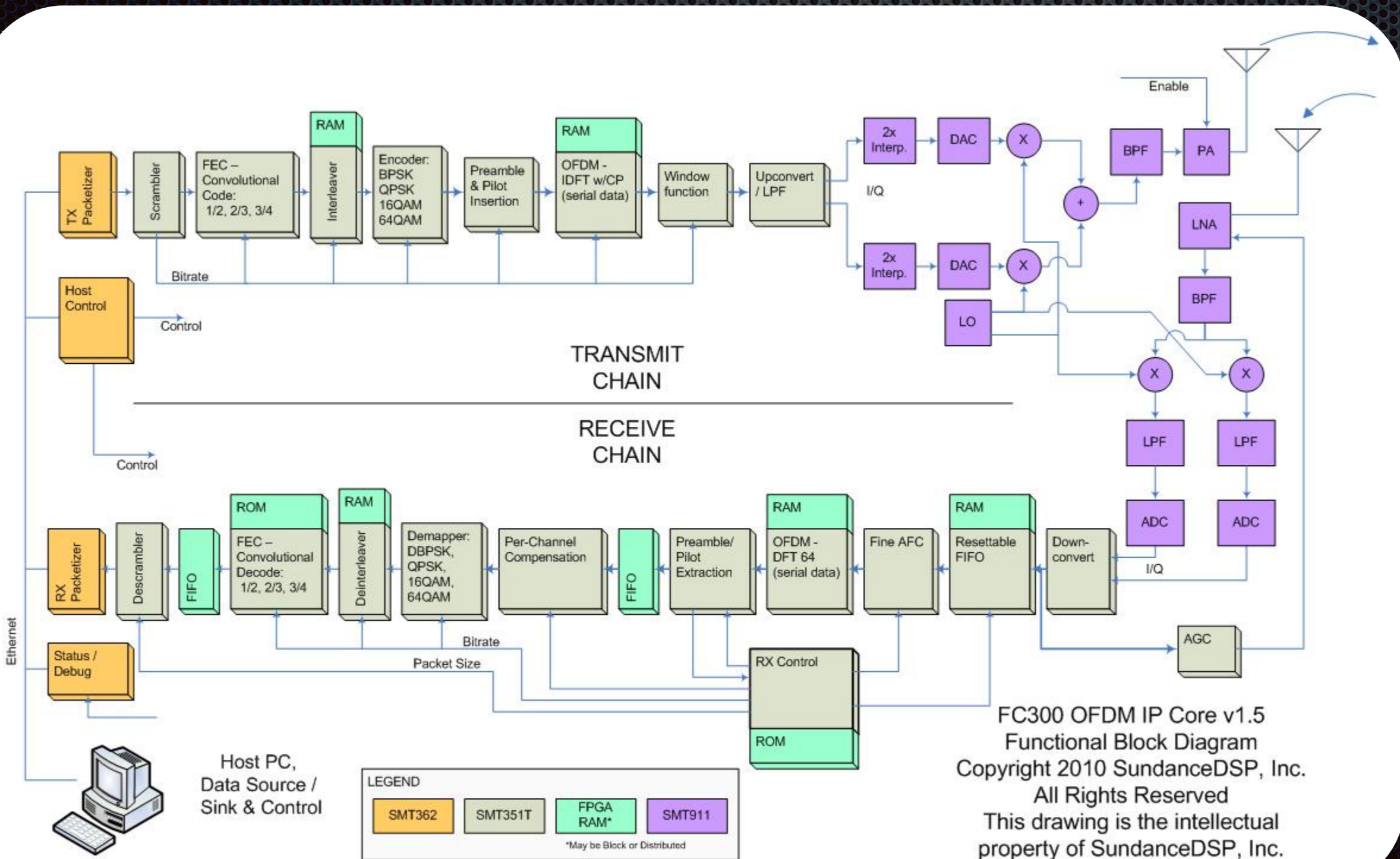



# GSM

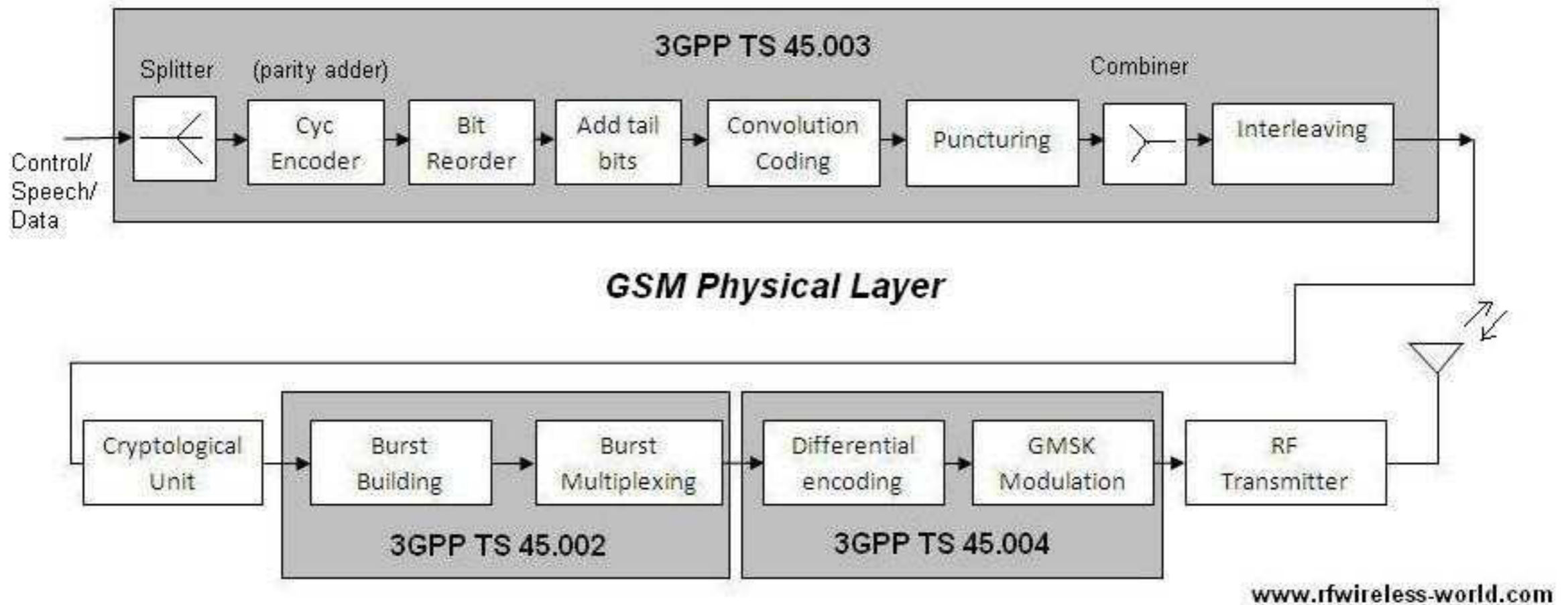



# CDMA2000

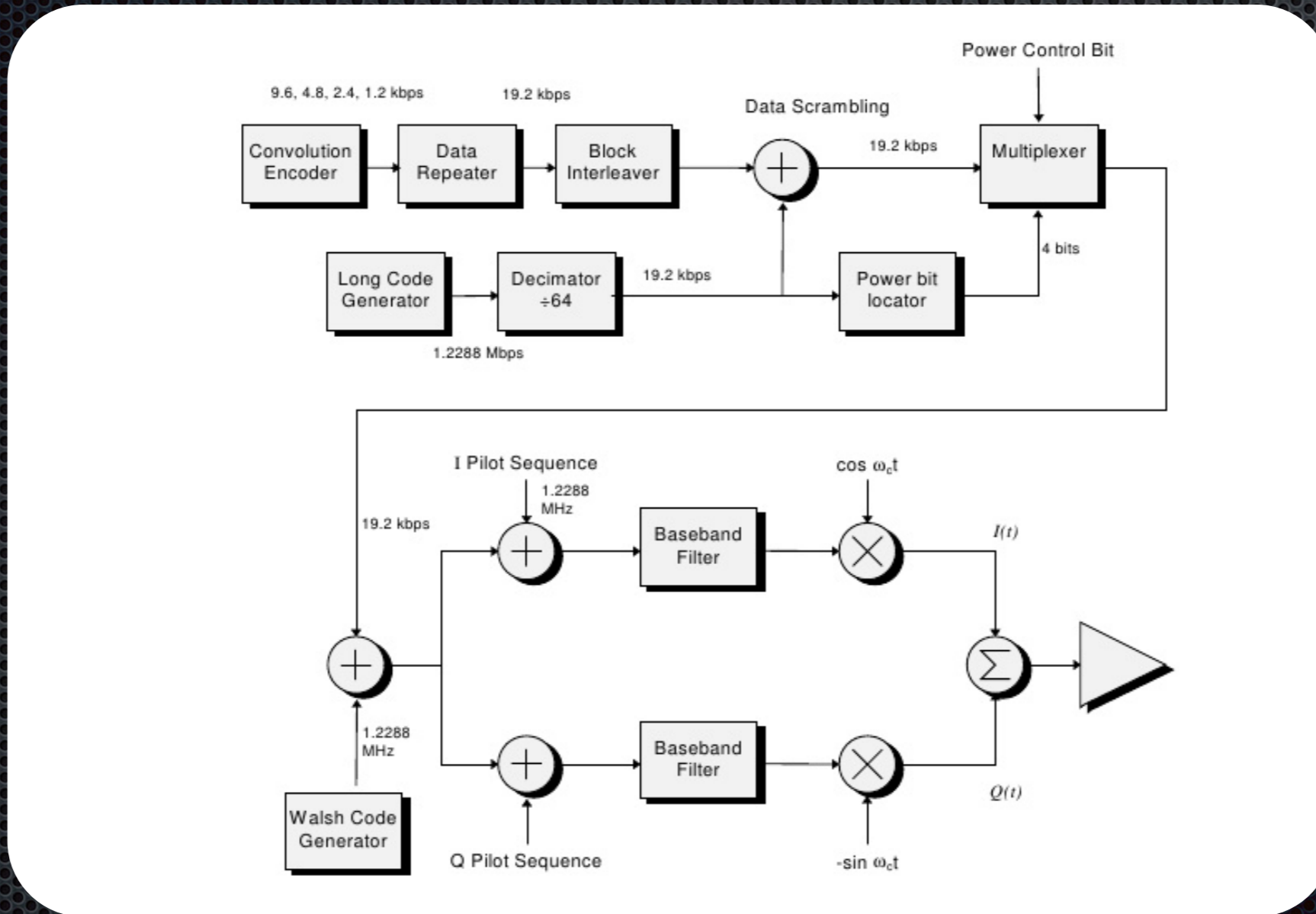



# DVB-T

